

Magnetic rotary angle and position sensor-control

Rotary concentric touchless sensor

PS2P-CON

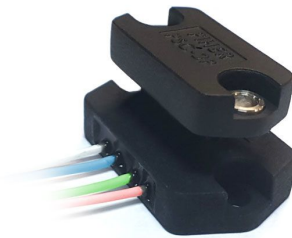

Main features

- True touchless operation: free from wear and tear.
- Low profile & robust magnetic design that easily adapts to your design.
- Selectable output: analogue (ratiometric) or PWM. SPI upon request.
- Programmable angular range up to 360 degrees.
- Nominal air gap: 3mm between plastic parts.
- Maximum air gap: 5mm. For higher air gap: check availability.
- Maximum magnet radial offset allowed: ± 3 mm. (Measured directly on non-ferromagnetic material. For other configurations check with Piher.)
- Resolution: analogue & PWM: 12 bits / SPI: 14 bits.
- Linearity: $\pm 1\%$ absolute ($\pm 0.5\%$ upon request).
- Over voltage protection.
- Reverse voltage protection.
- Supply voltage up to 25V.
- Programmable Linear Transfer Characteristic. (Some positive slopes & one negative slope can be programmed in the same transfer characteristic; up to 4 programmable points)
- Unlimited mechanical life.
- High vertical & lateral tolerance to magnet misalignment.
- Simple, redundant and full redundant versions available.
- Sealed for harsh environments.
- Operating temperature: -40°C to $+125^{\circ}\text{C}$.
- Self-diagnostic features.

Touchless working principle

Measurement of angular position using variation of magnetic field amplitude induced by the displacement of a moving magnet has been intensively developed over the last fifteen years. However, these solutions have limits in terms of angular range and temperature influence.

The technology used by Piher is only sensitive to the flux density coplanar with the IC surface.

The angular information is computed from both vectorial components of the flux density (i.e. BX and BY) of a magnet. Then an output signal proportional to the decoded angle is produced.

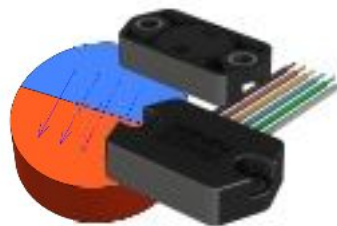

Markets served

- Agriculture.
- Construction & forestry.
- Material handling.
- Lifts & cranes.
- Marine.
- Medical.

Description

Something that is truly contactless. One magnet, One electronics module. No gears. Nothing to wear out over a lifetime.

A sensor that will deliver the same level of precision and stability throughout its life as the first day it was installed - despite extremes of vibration, shock, temperature and contamination. Something that is easy to assemble - delivering additional cost reduction on the production line.

Something that can be fitted anywhere on the pivoting shaft, giving engineers the flexibility to be creative.

Our touchless sensor is Piher Sensing Systems at its best, packaging its core technology - slimline magnetic Hall Effect sensing - into something truly original.

Sensing the position, avoiding contact

The concentric touchless linear sensors create immunity to magnet's misalignment that negatively impacts operational performance and results in labour intensive maintenance programmes. It complements our linear and variable air-gap touchless series of non-contact angular rotary position sensors.

The magnet is attached to the moving parts whose displacement is to be measured, such as hydraulic/pneumatic controls or gear selector, and the electronics module is fixed to the chassis (or vice versa).

As absolute sensors, they will not lose the values even after a power failure.

All Piher touchless sensors are compact, sealed, low-profile, yet extremely rugged and can be custom-engineered to fit customer's specifications and existing mechanical assemblies.

Magnetic rotary angle and position sensor-control

Rotary concentric touchless sensor

PS2P-CON

How to order (example: PS2P-CON-CE-M001-1A0-C000-ERA015-05-F100)

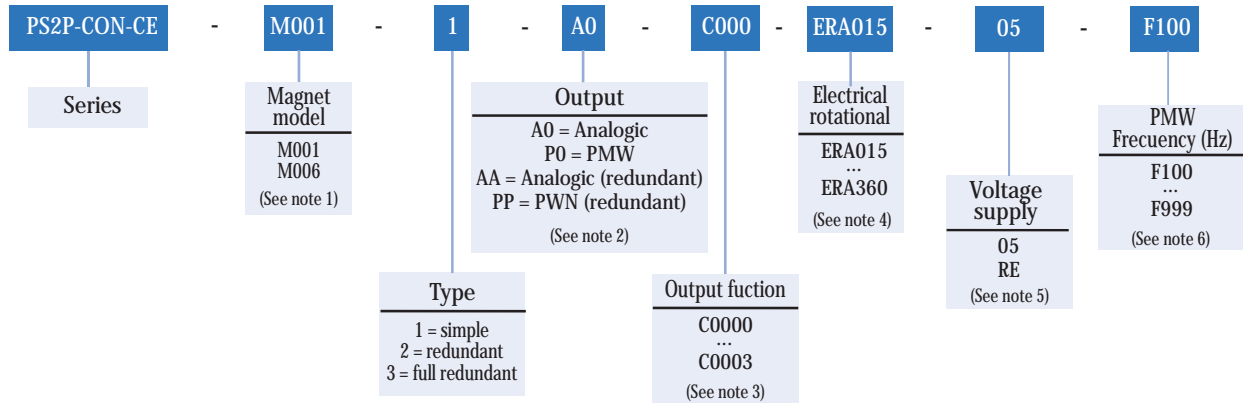

NOTES

(1) **M001**
Magnet for concentric rotary sensing



M006
Magnet for concentric rotary sensing



(2) The analog output is a ratiometric output, proportional to:
 - For supply voltage 5V: to input supply voltage.
 - For supply voltage RE: to 5V.

(3) Other output functions available check availability.
 In the How To Order reference, enter CXXXX meanwhile the new output function reference is not defined.
 Standard output functions:

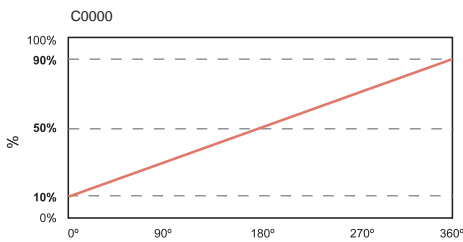

→ CW

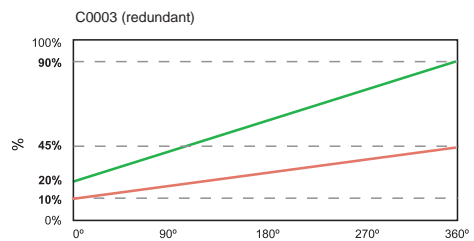
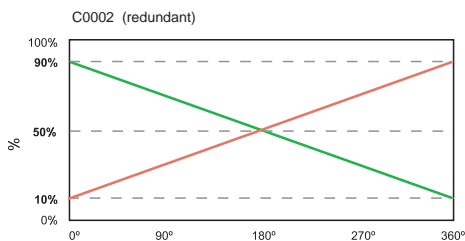
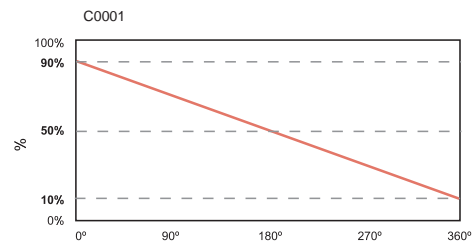

(4) ERA = electrical rotational angle measured in degrees. Examples:
 ERA015 = 15 degrees electrical rotational angle (minimum).
 ERA150 = 150 degrees electrical rotational angle.
 ERA360 = 360 degrees electrical rotational angle.

(5) 05: 5V ±10%
 RE: 7V - 25V
 RE not available for full redundant versions.

(6) Leave empty if no applicable. Default frequency is 200 Hz
 For redundant versions, please, write both frequencies: -FXXXXFXXX

Magnetic rotary angle and position sensor-control

Rotary concentric touchless sensor

PS2P-CON

Dimensions

Drawings may not be to scale. Number and function of wires pictured in this datasheet may vary according to the selected output configuration.

Dimensions in mm with magnet M001

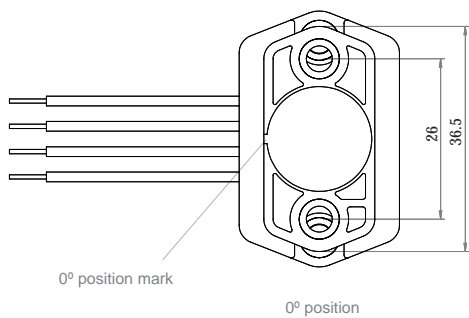
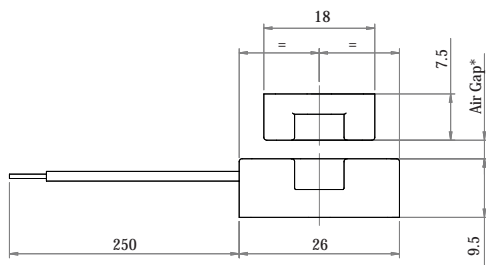
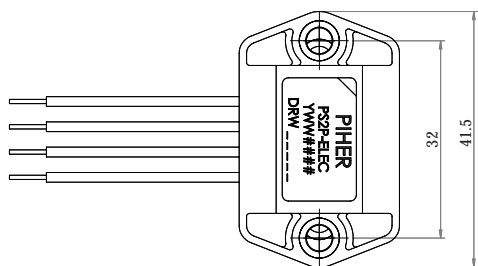

* Nominal air gap: 3mm
For higher air gap please contact sales@piher.net

Dimensions in mm with magnet M006

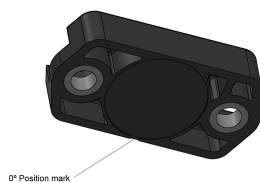
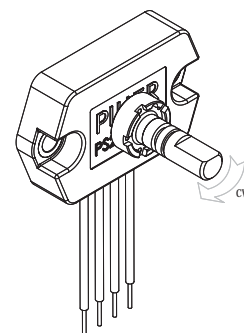
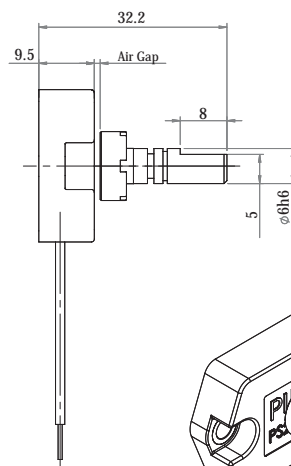
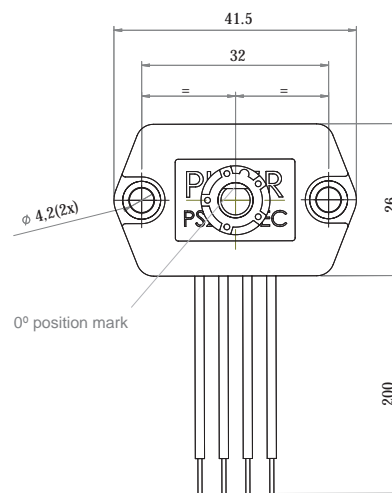

Instructions
of use available at
www.piher.net



Download the STEP file here:
<https://piher.net/piher/?p=932>

PS2P-CON. Specifications & standards

Rotary concentric touchless sensor

Mechanical specifications

| | | |
|---------------------------------|---------------|------------------------------|
| Vibration | EN 60068-2-6 | 5-2000 Hz; 20g; Amax 0,75 mm |
| Shock | EN 60068-2-27 | 50g |
| IP sealing | IEC 60529 | IP67 |
| Operating & storage temperature | °C | -40 to +125 |
| Life | movements | no limit |
| Mechanical range | degrees | 360 (continuous rotation) |

Check availability for other specifications

Standards

| | |
|--|-------------------|
| CISPR 16-2-3 class B emission radiated (30 ... 230MHz) | max. 30 dB (µV/m) |
| CISPR 16-2-3 class B, emission radiated (230 ... 1000MHz) | max. 37 dB (µV/m) |
| EN 61000-4-2, ESD on housing and connections (contact/air) | ±4 / ±8 kV |
| EN 61000-4-4, Burst (on supply lines / signal lines) | ±1 kV |
| EN 61000-4-5, Surge (on supply lines / signal lines) | ±1 kV |
| EN 61000-4-3, immunity HF radiated (80 ... 2000 MHz) | 10 V/m |
| EN 61000-4-6, immunity HF conducted (0,15 ... 80MHz) | 10 Vemk |
| EN 61000-4-8, immunity magnetic field (50 Hz) | 30 A/m |

Disclaimer

Ferromagnetic parts close to the sensor environment may modify the performance of the sensor. Therefore, this has to be communicated to Piher for prior analysis.

No external magnetic perturbations are considered on the application where the sensor is mounted. If so, amplitude and direction of flux density generator type and characteristics (magnet, cable, motor...) must be notified to Piher for a magnetic simulation analysis update.

The information in this sheet is preliminary and for reference purposes only. Please consult for the most up to date and accurate design information.

Piher Sensors & Controls S.A., its affiliates, agents, and employees, and all persons acting on its or their behalf (collectively, "Piher"), disclaim any and all liability for any errors, inaccuracies or incompleteness contained herein or in any other disclosure relating to any product described herein.

Piher disclaims any and all liability arising out of the use or application of any product described herein or of any information provided herein to the maximum extent permitted by law. The product specifications do not expand or otherwise modify Piher's terms and conditions of sale, including but not limited to the warranty expressed therein, which apply to these products.

No licence, express or implied, by estoppel or otherwise, to any intellectual property rights is granted by this document or by any conduct of Piher.

The products shown herein are not designed for use in medical, life-saving, or life-sustaining applications unless otherwise expressly indicated. Customers using or selling Piher products not expressly indicated for use in such applications do so entirely at their own risk and agree to fully indemnify Piher for any damages arising or resulting from such use or sale. Please contact authorised Piher personnel to obtain written terms and conditions regarding products designed for such applications.

Product names and markings noted herein may be trademarks of their respective owners.

Piher is an Amphenol™ company.



RoHS
compliant

Information contained in and/or attached to this catalogue may be subject to export control regulations of the European Community, USA, or other countries. Each recipient of this document is responsible to ensure that usage and/or transfer of any information contained in this document complies with all relevant export control regulations. If you are in any doubt about the export control restrictions that apply to this information, please contact the sender immediately. For any Piher Exports, Note: All products / technologies are EAR99 Classified commodities. Exports from the United States are in accordance with the Export Administration Regulations. Diversion contrary to US law is prohibited.

All Piher products can be adapted to meet customer's requirements. Consider the environment before printing.
Please always use the latest updated datasheets published at our website www.piher.net.

v220720

