

ST-15

15-mm carbon endless rotation through-hole potentiometer

360° rotary control (CW or CCW) with highly configurable mechanical and electrical specifications such as a wide variety of off-the-shelf mounting methods, custom ohmic (resistance) values, tight linearity performance, different rotor designs, shafts and knobs and built-in stop positions.

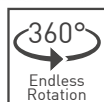
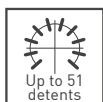
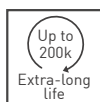
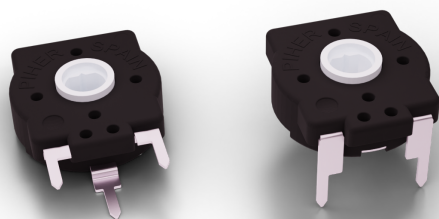

KEY FEATURES

- ▶ 360° mechanical rotation angle
- ▶ Up to 340° electrical rotation angle
- ▶ Up to 51 mechanical detents
- ▶ Up to 200.000 life cycles
- ▶ IP54 protection
- ▶ Cost-effective control potentiometer for home appliances and automotive
- ▶ Selection of shaft & knobs

On request

- ▶ Flame-retardant plastic materials
- ▶ Custom electrical angles
- ▶ SMD mount
- ▶ Controlled linearity up to 3%

ELECTRICAL SPECIFICATIONS	
Taper	Linear
Range of values* (Decad. 1.0 - 2.0 - 2.2 - 2.5 - 4.7 - 5.0)	$1K\Omega \leq R_n \leq 100K\Omega$
Tolerance*	±30%
Max. Voltage	50 VDC
Nominal power 50°C (122°F)	0.25 W
Residual resistance	≤ 5% R _n
Equivalent noise resistance	≤ 3% R _n
Operating temperature **	-25°C to +70°C (-13°F to + 158°F)

* Others available on request ** Up to 85°C depending on application.

APPLICATIONS

- ▶ Appliance program selection
- ▶ Thermostat adjustment
- ▶ HVACR control / sensor
- ▶ Consumer electronics
- ▶ Power tool controls
- ▶ Automotive control

ST-15

15-mm carbon endless rotation potentiometer

MECHANICAL SPECIFICATIONS

Mechanical rotation angle	Endless (360°)
Electrical rotation angle*	333° ±15°
Torque Standard Low	0.5 to 2.5 Ncm ≤ 1.5 Ncm
Life* Standard Long	1.000 cycles 10.000 cycles

* Others available on request

ENVIRONMENTAL TESTING

	Test method (CEI 393-1)	ΔR[%]- Piher typical test results
Electrical life	1.000h at 50°C; 0.15W	±5%
Mechanical life	1000 cycles at 10 to 15 cpm	±3 % (Rn < 1M)
Temperature coefficient	-25°C; +70°C	±300 ppm/°C (Rn < 100K)
Thermal cycling	16h at 85°C and 2h at -25°C	±2.5%
Damp heat	500h at 40°C and 95% relative humidity (RH)	±5%
Vibration	2h each plane at 10Hz - 55Hz	±2%
Storage	6 month at 23°C ±2°C and 50% RH	±2.5%

Out of range values may not comply with these results. Standard test conditions: temperature:23°C ±2°C and 45% to 70% RH

RECOMMENDED CONNECTIONS

Recommended connection circuit for a position sensor or control application (voltage divider circuit electronic design).

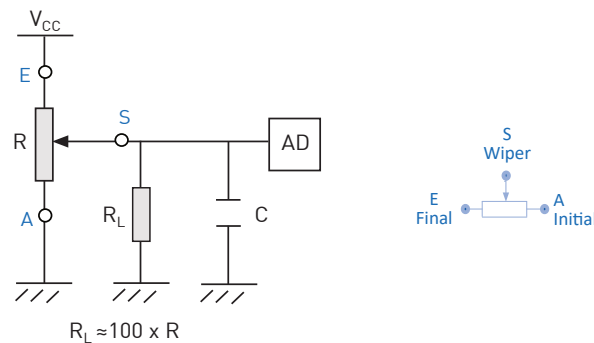

POWER RATING CURVE

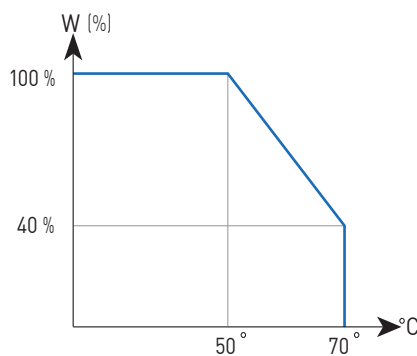

ST-15

15-mm carbon endless rotation through-hole potentiometer

HOW TO ORDER (EXAMPLE: ST15LH01-223A3030-PM-S)

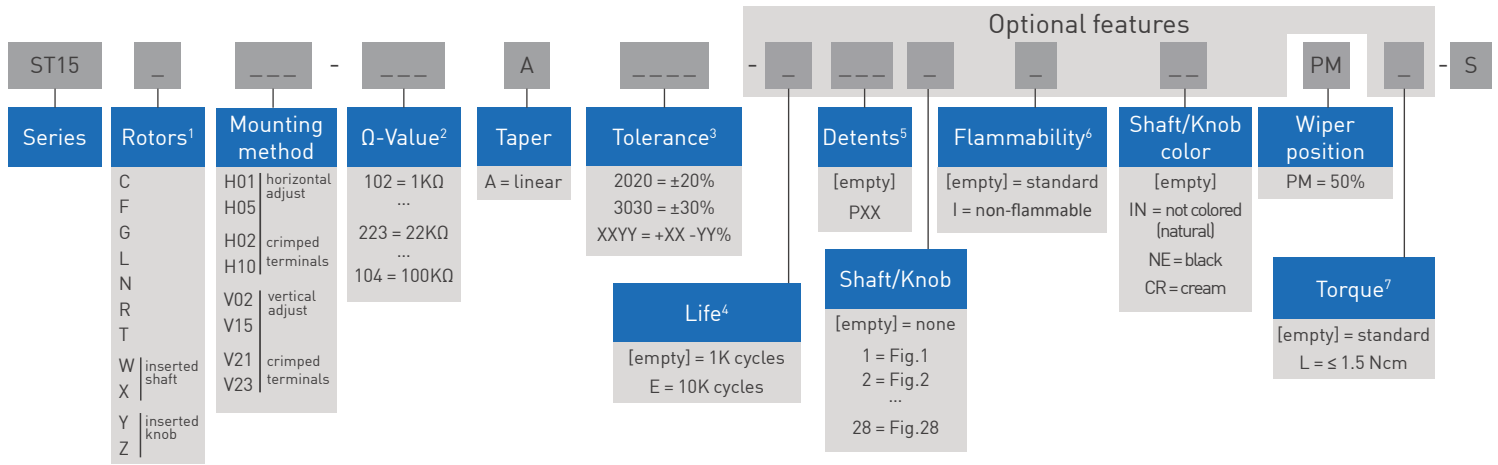

1. Rotors: "Z" adjustment only available on "H". Standard color for the "T" rotor is Orange
2. Ω- Value: XXX - First two digits of Ω-value
XXX - Number of zeros
3. Tolerance: for custom tolerance please check availability
4. Life: up to 200k cycles upon request
5. Detents: use "P" followed by detent number. Max. number of detents is 51. Example for 4 detents: P04
6. Non-flammable according to UL 94V-0: housing, rotor and shaft
7. Torque: detent option not available with low torque models

DEFAULT CONFIGURATION

Life	1.000 cycles (forth and back the mechanical angle travel)
Detents	none
Housing color	black
Rotor color	white
Shaft/knob/thumbwheel color (if applicable)	Not colored (natural)
Wiper position	50%
Torque	0.5 to 2.5 Ncm
Resistive tolerance	±30%
Packaging	bulk

ORDER CODE EXAMPLES

ST15RV02-104A3030-PM-S
Potentiometer with rotor type "R", V02 mounting method (vertical adjustment), 100K resistive value, linear taper and 30% resistive tolerance.

ST15WV15-103A3030-22NEPM-S
Potentiometer with factory-inserted black shaft ref. 6029 , V15 mounting method (vertical adjustment), 10K resistive value, linear taper and 30% resistive tolerance.

ST-15

15-mm carbon endless rotation through-hole potentiometer

MOUNTING METHOD

V21 = Vertical Adjustment - Horizontal Mounting - Crimped Terminals

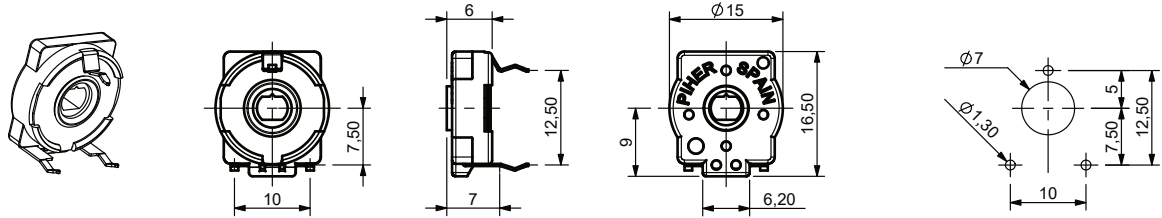

V23 = Vertical Adjustment - Horizontal Mounting - Crimped Terminals

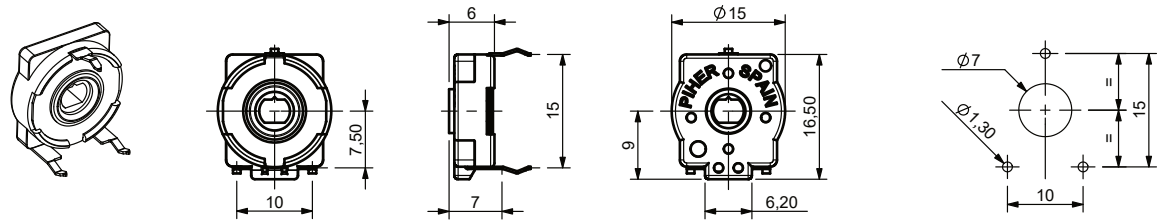

H01 = Horizontal Adjustment - Vertical Mounting

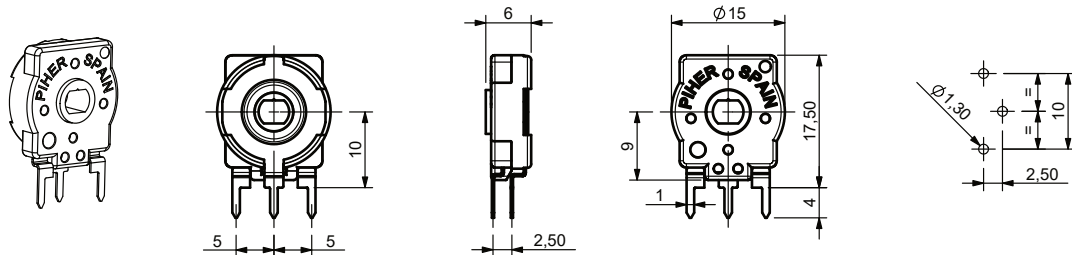

H02 = Horizontal Adjustment - Vertical Mounting - Crimped Terminals

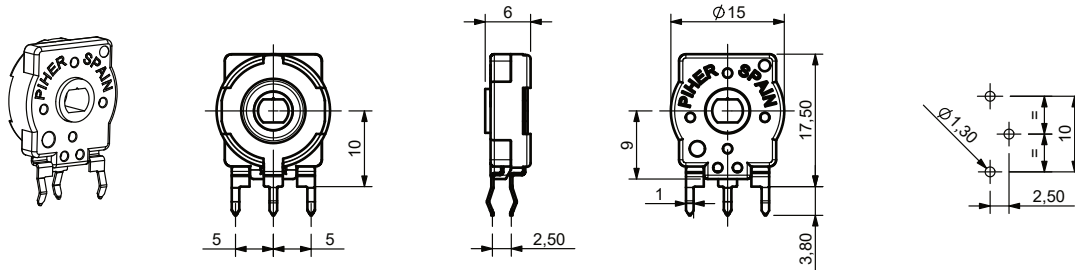

H05 = Horizontal Adjustment - Vertical Mounting

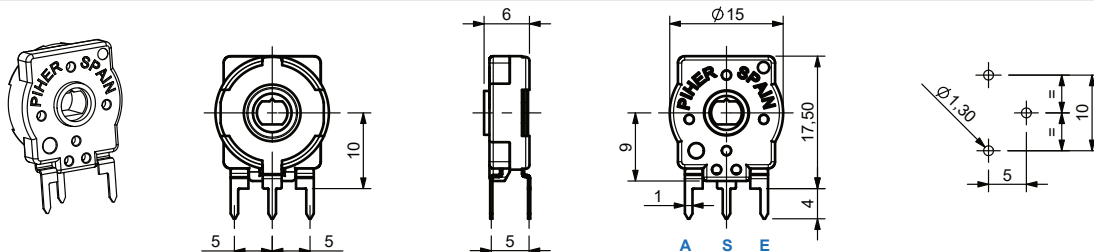

 Download STEP files here: www.pihernet.net

ST-15

15-mm carbon endless rotation through-hole potentiometer

MOUNTING METHOD

H10 = Horizontal Adjustment - Vertical Mounting - Crimped Terminals

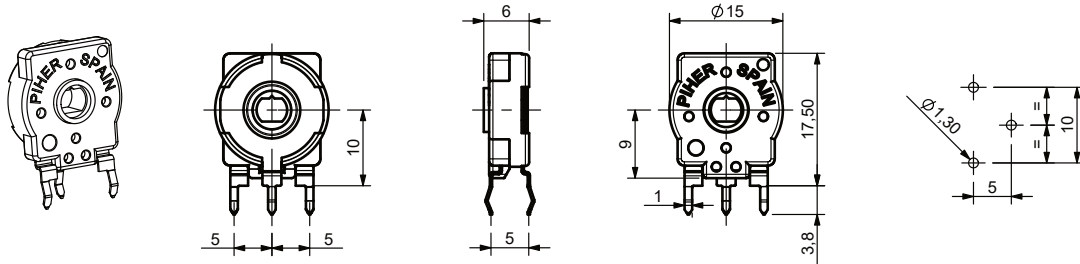

CRIMPED TERMINALS (DETAIL)

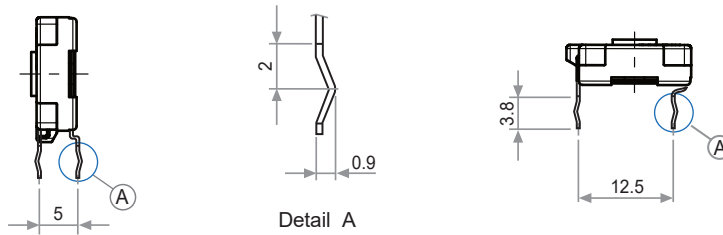

SMD MOUNTING AVAILABLE

STS-15

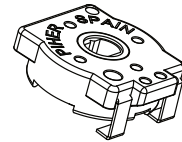
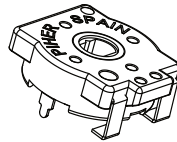
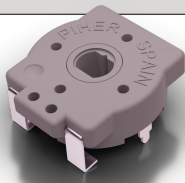

For more information visit: www.piher.net

PANEL MOUNT VERSION

STM-15

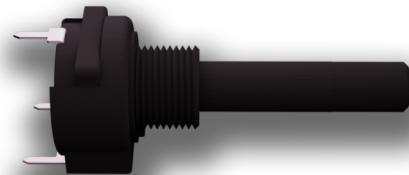
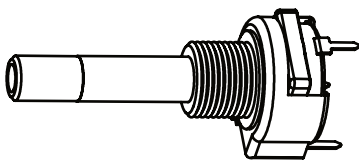

Check available models at info@piher.net

DETENTS (STOP POSITIONS)

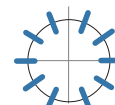
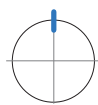
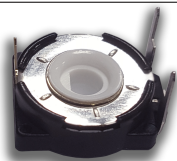

— Relative detent positions examples along total mechanical travel

- Standard mechanical life may change.
- This feature has been specifically developed to allow the integration of otherwise large and expensive external mechanisms into the body of the potentiometer thus allowing a high range of configurations: special tapers, torque, tolerances, linearity, etc.
- This detent design not only adds a "click" sensation of position, but also offers enormous savings in both cost and space for any given application.
- Strong and weak detents can be mixed as per customer's request (up to 51).
- Detent number and positions can be made or fitted to the customer needs or preferences.

ST-15

15-mm carbon endless rotation through-hole potentiometer

STEPPED OUTPUTS / CONSTANT VALUE ZONES

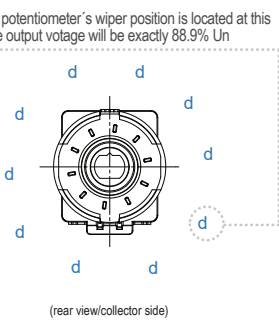
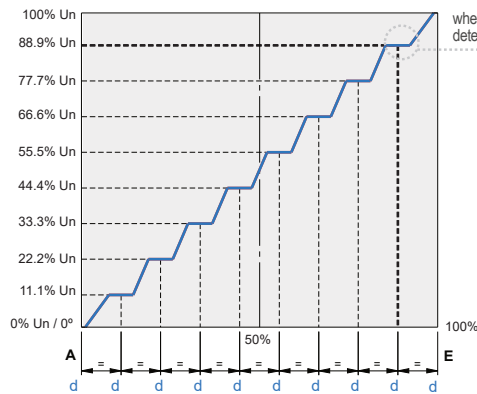

IMPROVED REPEATABILITY

Constant value zones can be combined with strategically located mechanical detents to provide exact alignment between the electrical output (flat areas) and the mechanical detent position. This provides clear mechanical positions that are not only repeatable, but perfectly aligned electrical outputs at each of the (detent) angles. The detents also prevent output values from changing due to vibration or accidental rotor movements. The result is a higher level of precision in controlling lighting, temperature, motor or other electronic control systems.

Contact Piher Sensing Systems for ordering information.

PACKAGING

Bulk



- Without shaft: 400 units per box
- With thumbweel: 200 units per box
- With shaft: contact Piher Sensing Systems

Dimensions (mm): 185x85x80

SHAFTS AND THUMBWHEELS (TOP VIEW, FOR N, G AND T ROTOR TYPES)

Hollow shafts models

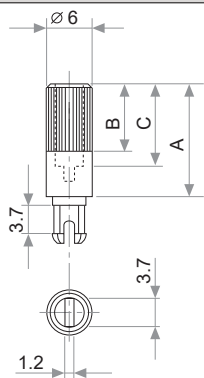

Fig.	Ref.	A	B	C
1	5272	12	9	8
2	5214	19	9	15
5	5208	9.5	6.5	5.5
9	5216	35	9	31
10	5218	37.8	9	33.8
11	5209	35	25	31

A = Length measured from rotor surface
 B = Knurling length
 C = Hollow depth

Solid shafts models

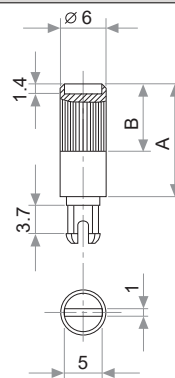

Fig.	Ref.	A	B
6	5219	15	9
7	5220	16.8	9
8	5207	25.3	9
12	5227	46	5

Slot (1 x 1.4) perpendicular to wiper position.
 Fig. 12 slot is on line with wiper position.

Fig. 3 - Ref. 5372	Fig. 15 - Ref. 5217	Fig. 17 - Ref. 5210	Fig. 18 - Ref. 5271	Fig. 19 - Ref. 6032*	Fig. 20 - Ref. 5369*

ST-15

15-mm carbon endless rotation through-hole potentiometer

SHAFTS AND THUMBWHEELS (TOP VIEW, FOR N, G AND T ROTOR TYPES)

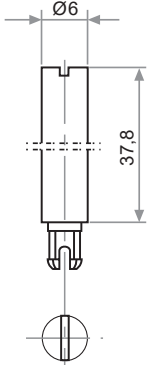
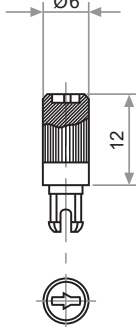
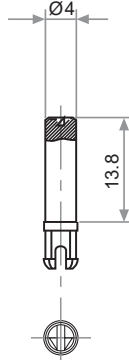
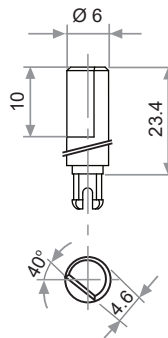
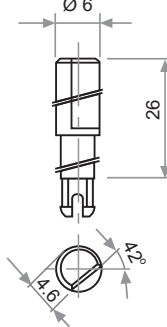
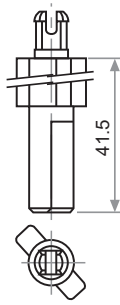
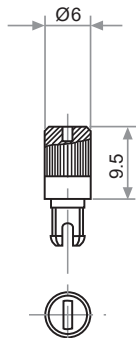
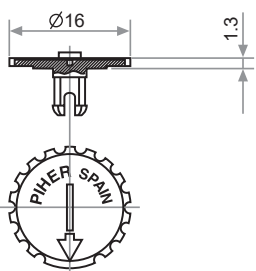
Fig. 21 - Ref. 6031*	Fig. 22 - Ref. 6029	Fig. 23 - Ref. 6022	Fig. 29 - Ref. 6162	Fig. 25 - Ref. 6059	Fig. 27 - Ref. 5268*
					
Fig. 28 - Ref. 6055		Fig. 4 - Ref. 5371			
					
		<p>By default, shafts, knobs and thumbwheels are delivered unassembled. If you need the shaft or knob to be delivered assembled from the factory, please select the appropriate rotor in the part number: X, W, Y or Z.</p> <p>On request, shafts, knobs and thumbwheels can be delivered at specific positions on request. Otherwise they are delivered at random position.</p> <p>The plastic color can be stated in the part number.</p> <p>Non flammable plastic available, if potentiometer is orderer with non-flammable plastic (UL-94V0), the shaft, knob or thumbwheels will be delivered with non-flammable plastic.</p> <p>If you wish to use your own plastic shaft/knob/actuator please contact Piher for advice about compatible materials.</p>			

* Not available in self-extinguishable plastic.

OUR ADVANTAGE

- ▶ Leading-edge innovative position sensing solutions
 - ▷ Contactless (Hall-effect and Inductive Technology)
 - ▷ Contacting (Potentiometers, Printed Electronics)
- ▶ Engineering design-in support
- ▶ All our products can be customized to fit target application and customer requirement
- ▶ Capability to move seamlessly from development to true high-volume production
- ▶ A global footprint with global engineering and commercial support
- ▶ One-stop shop not limited to position sensors (temperature, pressure, gas,...) through group collaboration
- ▶ Flexibility and entrepreneurship of a medium-sized company with the backing of Amphenol Corporation



Please always use the latest updated datasheets and 3D models published on our website.

Disclaimer:

The product information in this catalog is for reference purposes. Please consult for the most up to date and accurate design information. Piher Sensors & Controls S.A., its affiliates, agents, and employees, and all persons acting on its or their behalf (collectively, "Piher"), disclaim any and all liability for any errors, inaccuracies or incompleteness contained herein or in any other disclosure relating to any product described herein. Piher disclaims any and all liability arising out of the use or application of any product described herein or of any information provided herein to the maximum extent permitted by law. The product specifications do not expand or otherwise modify Piher's terms and conditions of sale, including but not limited to the warranty expressed therein, which apply to these products. No license, express or implied, by estoppel or otherwise, to any intellectual property rights is granted by this document or by any conduct of Piher. The products shown herein are not designed for use in medical, life-saving, or life-sustaining applications unless otherwise expressly indicated. Customers using or selling Piher products not expressly indicated for use in such applications do so entirely at their own risk and agree to fully indemnify Piher for any damages arising or resulting from such use or sale. Please contact authorized Piher personnel to obtain written terms and conditions regarding products designed for such applications. Product names and markings noted herein may be trademarks of their respective owners. Information contained in and/or attached to this catalogue may be subject to export control regulations of the European Community, USA, or other countries. Each recipient of this document is responsible to ensure that usage and/or transfer of any information contained in this document complies with all relevant export control regulations. If you are in any doubt about the export control restrictions that apply to this information, please contact the sender immediately. For any Piher Exports, Note: All products / technologies are EAR99 Classified commodities. Exports from the United States are in accordance with the Export Administration Regulations. Diversion contrary to US law is prohibited.

CONTACT

Piher Sensing Systems
 Polígono Industrial Municipal
 Vial T2, Nº22
 31500 Tudela
 Spain

sales@piher.net

Europe: +34 948 820 450
 Americas: +1 636 251 0855
 Asia Pacific: +65 9641 8886

Rev-29/02/24 © 2022 Piher Sensors & Controls S.A.